

NIAGARA BLOWER COMPANY

No-FROST[®] REFRIGERATION SYSTEMS

New A-Type Concentrator Electric Heater Upgrade

Niagara introduces its electric pan heater upgrade for A-Type concentrators

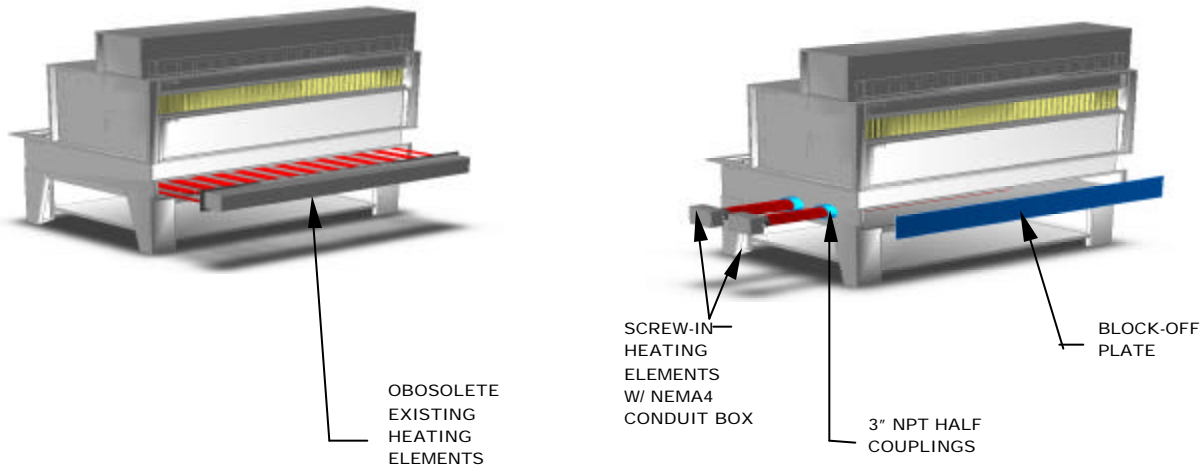

Older obsolete electric pan heaters

New screw-in electric pan heaters

Screw-in pan heaters are retrofitted in four (4) easy steps:

- Step 1: Remove existing heaters
- Step 2: Install and full weld block-off plate
- Step 3: Install (2) two 3" NPT half couplings
- Step 4: Insert new screw-in heating elements and re-wire

Note: Niagara's electric heater retrofit package comes complete with; block-off plate, couplings, screw-in heater elements and installation instructions.

ADVANTAGES

- Easily removed for replacement
- Increase reliability
- Easily retrofitted to older concentrators
- Reduced maintenance requirements

For more information about this as well as other No-Frost[®] system upgrades, please contact the Niagara factory offices in Buffalo, NY.

